

Automotive Solenoid Coil

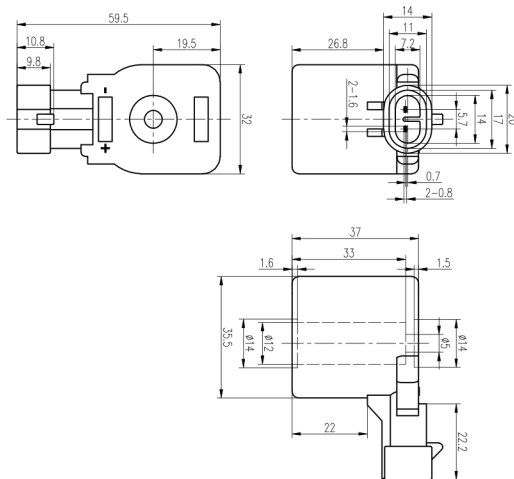

产品型号 / Coil type.:12372

产品编号 / Code no.:BRS-C023



技术参数 / Technical Data

标称电压 Standard Voltage	12VDC/24VDC,others on request
电压范围 Voltage range	DC: -25%~+30%
额定功率 Rated Power	DC: 24W,others on request 其它可定制
工作时间 Duty Cycle	ED100% (continuous)

保护等级 Protection degree	IP65(EN60529)
绝缘等级 Coil Insulation	Class R
环境温度 Ambient temperature	-40°C~+120°C
工作频率 Frequency	50/ 60 HZ

主要结构 / General Construction

骨架材料 Bobbin material	PBT/PA66/PPS/PET
铜线等级 Coil wire	Class H wire,-200°C (IEC317-8)
支架 Magnetic yoke	Made by low carbon iron 高导磁低碳钢
封塑材料 Encapsulation material	PA66 30% fiberglass thermoplastic material 热塑性塑封料

接电方式 / Electrical Connections

DEUTCH

应用 / Application

适用于汽车 SCR 系统电磁阀。

Use for Automotive SCR System.